

REMOVAL AND INSTALLATION

Parking Brake Cable — Rear

Removal and Installation

All vehicles

1. With the vehicle in NEUTRAL, position it on a hoist. For additional information, refer to Section 100-02.
2. Release the tension on the parking brake cable. For additional information, refer to Parking Brake Cable Tension Release in this section.

Convertible vehicles

3. Remove and discard the appropriate support brace rear bolts.
 - To install, tighten to 63 Nm (46 lb-ft).

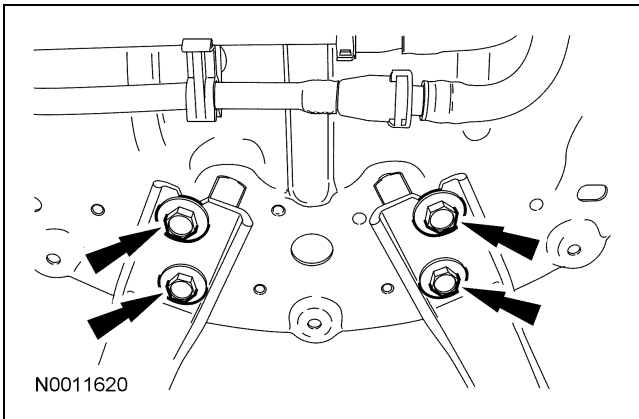

4. Remove and discard the appropriate support brace upper bolts.
 - To install, tighten to 63 Nm (46 lb-ft).

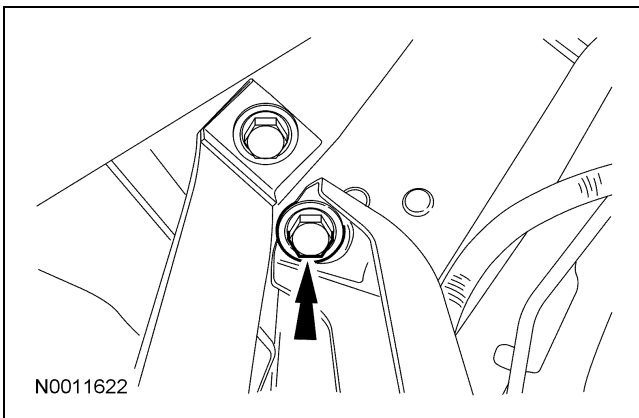

5. Remove and discard the appropriate support brace front bolts.
 - To install, tighten to 63 Nm (46 lb-ft).

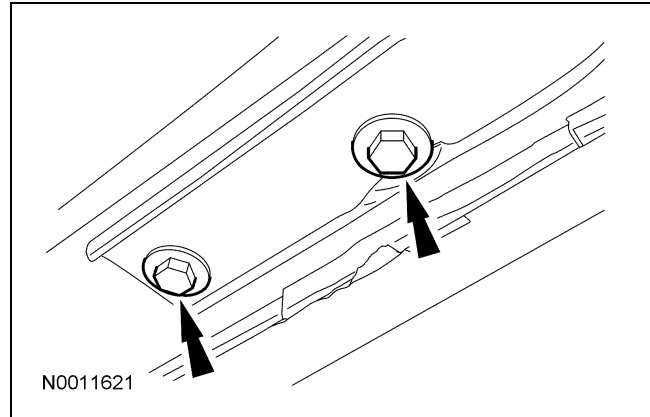

All vehicles

6. Disconnect the appropriate rear parking brake cable from the front parking brake cable at the equalizer, and release the cable from the body bracket.

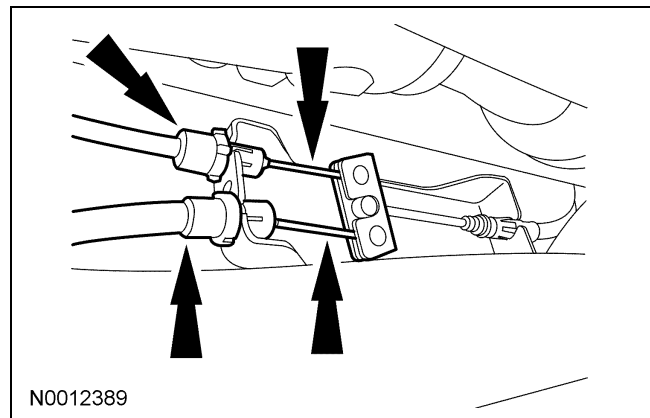

REMOVAL AND INSTALLATION (Continued)

7.  **CAUTION:** Verify that the boot is attached to the conduit end fitting and the strand end fitting. A clamp must be secured on the strand end fitting (t-end). There should be no exposed strand at the wheel end of the parking brake cable.

Remove the parking brake cable retaining clip from the parking brake cable, and disconnect the rear parking brake cable from the brake caliper.

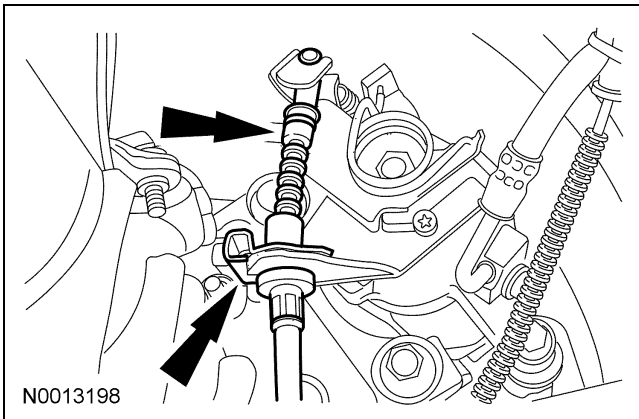

8. Remove the parking brake cable bracket bolt.
- To install, tighten to 35 Nm (26 lb-ft).
9. If removing the RH cable, remove the parking brake cable crossmember bracket bolt.
- To install, tighten to 20 Nm (15 lb-ft).
10. To install, reverse the removal procedure.
- Adjust the parking brake cable tension. For additional information, refer to the Parking Brake Cable Adjustment in this section.