



INSPECTION



TORQUE



CRITICAL PROCESS



ITEM NUMBER



OPERATION

*if an operation cannot be completed, contact a supervisor.

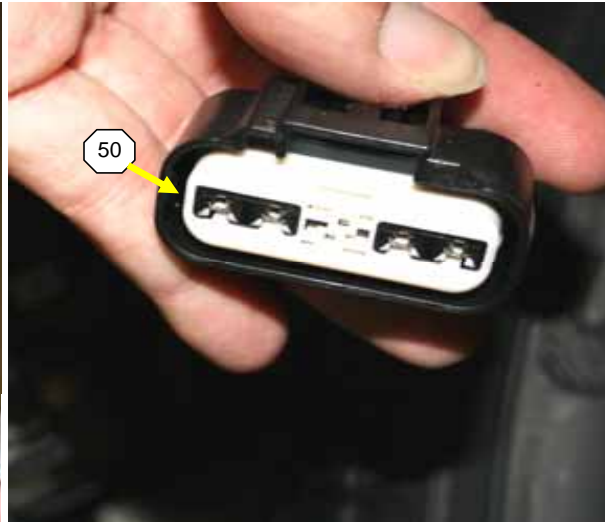
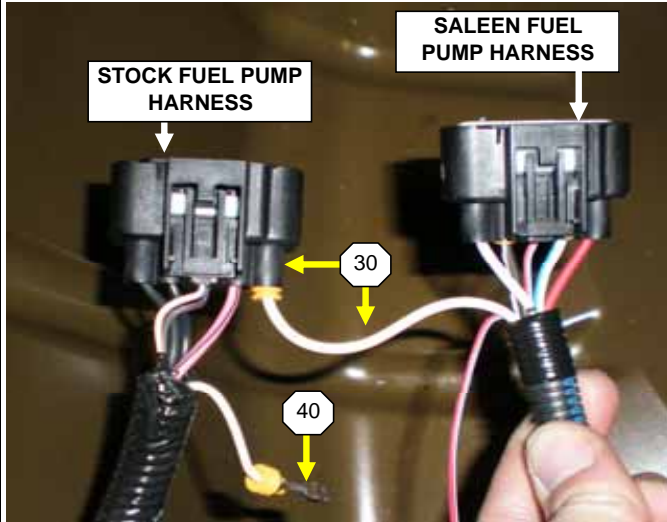
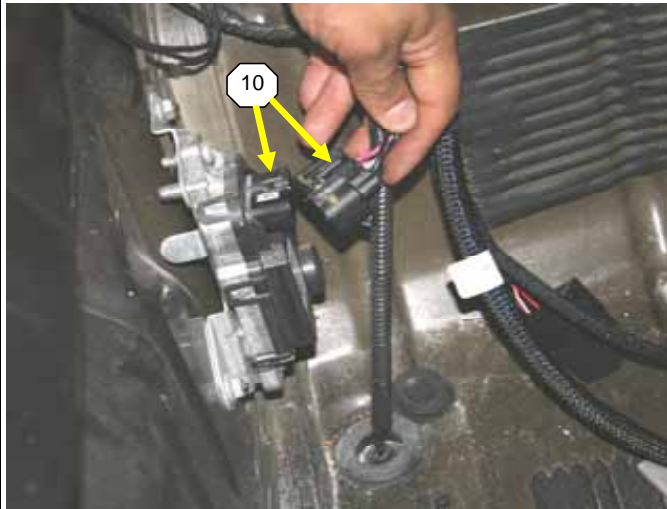

- 10 Go to the trunk and locate the stock fuel module with the stock harness plugged in and disconnect the harness.
- 20 Remove the white plastic insert from inside the fuel pump module plug and use a pick to pop out the white wire. **Only remove the white wire.**
- 30 The Saleen fuel pump harness has a pinned white wire not attached to a connector. Plug this pin into the stock fuel module connector in the same pin location the stock white wire used to be in.
- 40 Take the white wire on the stock fuel pump harness and bend it back against the harness and electric tape it to the harness. That wire will not be used.
- 50 Re-install the white plastic insert into the stock fuel pump harness connector.

ITEM	PART NUMBER	QTY.	DESCRIPTION

TORQUE



CHANGE	PROCESS CHANGE NUMBER	DATE	REVISION	DRAWN BY	ENG APPR	MNF APPR

CLIENT	PROGRAM
SALEEN (INTERNAL)	S302 EXTREME
PROCESS NAME	
FUEL PUMP HARNESS INSTALLATION	
PROCESS NUMBER	PAGE
S302E-LINE-1150	1 of 9



INSPECTION



TORQUE



CRITICAL PROCESS



ITEM NUMBER



OPERATION

*if an operation cannot be completed, contact a supervisor.

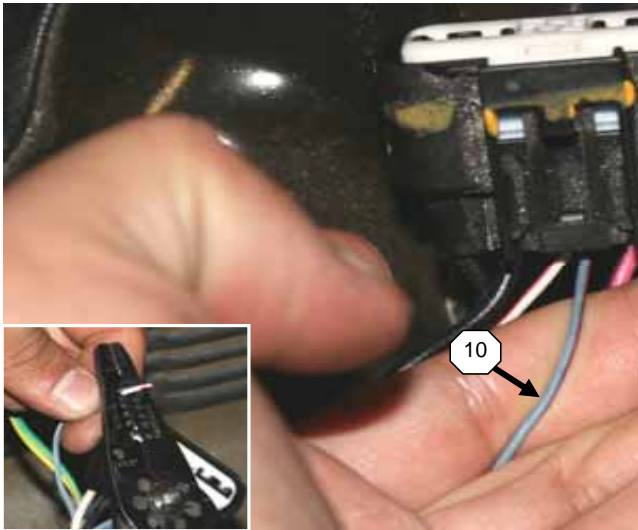

- 10 Locate the (blue w/red stripe) wire in pin 6 of the FPDM connector (on the stock fuel pump harness) and cut it at a distance 6" from the connector. Then strip the wire 1/4" back.
- 20 Find the remaining wire on the Saleen fuel pump harness (blue w/ red stripe) and strip the wire 1/4" back.
- 30 Slide a 1" piece of 3/16" heat shrink (A) over one of the wires and crimp the 2 wires (stock harness = blue w/ red stripe & Saleen harness = blue w/ red stripe) together. Then slide the heat shrink over the crimped butt splice (B) and apply heat to seal.
- 40 Take the relay and mount the relay to the rear trunk wall on the outboard side of the stock fuel module with one self tapping sheet metal screw (C).

ITEM	PART NUMBER	QTY.	DESCRIPTION
A	00-1704-C09486*	1"	Heat Shrink, Dual Wall 3/16"
B	00-1704-C09262*	1	Splice, Non-insulated 14-16 AWG Butt
C	069-310	1	Screw Pan Hd Phil Self Drill #8-18x1/2"

TORQUE



CHANGE	PROCESS CHANGE NUMBER	DATE	REVISION	DRAWN BY	ENG APPR	MAN APPR
1	PICTURE 20; OPERATION 20, 30	11/9/2007	Rev: Draft - Approved By Doc & Data Control	AJF		
		2/21/2008	Rev: 1 - Updated Picture & Operations For New Level Harness	AJF		

CLIENT	PROGRAM
SALEEN (INTERNAL)	S302 EXTREME
PROCESS NAME	
FUEL PUMP HARNESS INSTALLATION	
PROCESS NUMBER	PAGE
S302E-LINE-1150	2 of 9



INSPECTION



TORQUE



CRITICAL PROCESS



ITEM NUMBER



OPERATION

*if an operation cannot be completed, contact a supervisor.

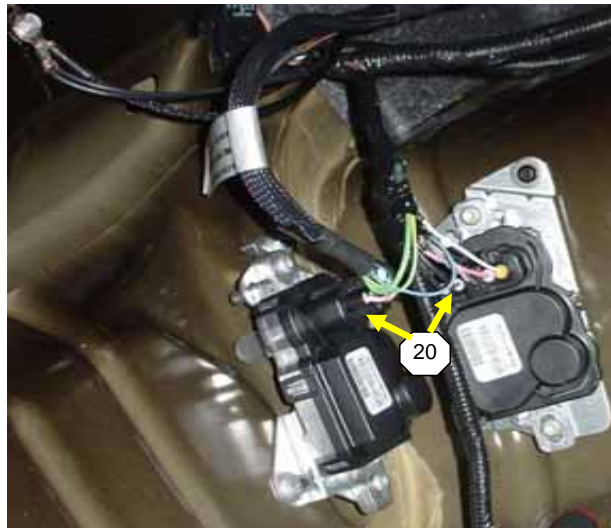
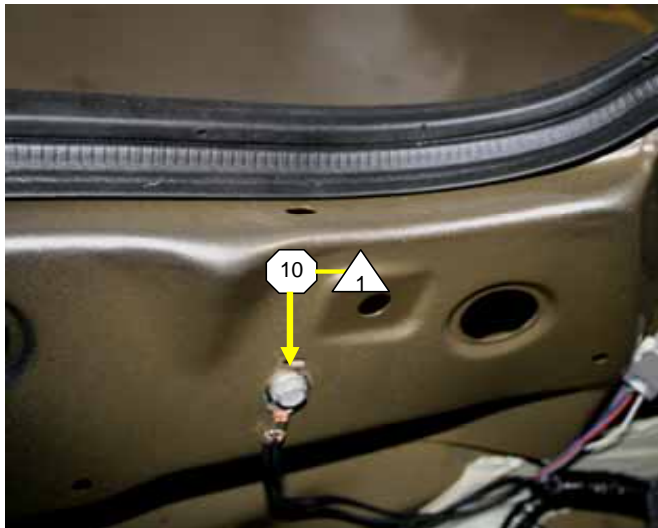

10

Attach the ground from the Saleen fuel pump harness to a nearby ground bolt in the trunk (on the rear wall of the trunk towards the driver (LH) side).

20

Plug the two fuel pump harness connectors into their respective fuel pump modules (stock fuel pump harness plug -to- stock fuel module & Saleen fuel pump harness plug -to- Saleen fuel pump module).

30

Use 4 zip ties (A) to fasten the fuel Saleen fuel pump harness to the existing harness running from the trunk into the passenger compartment (on the driver (LH) side).

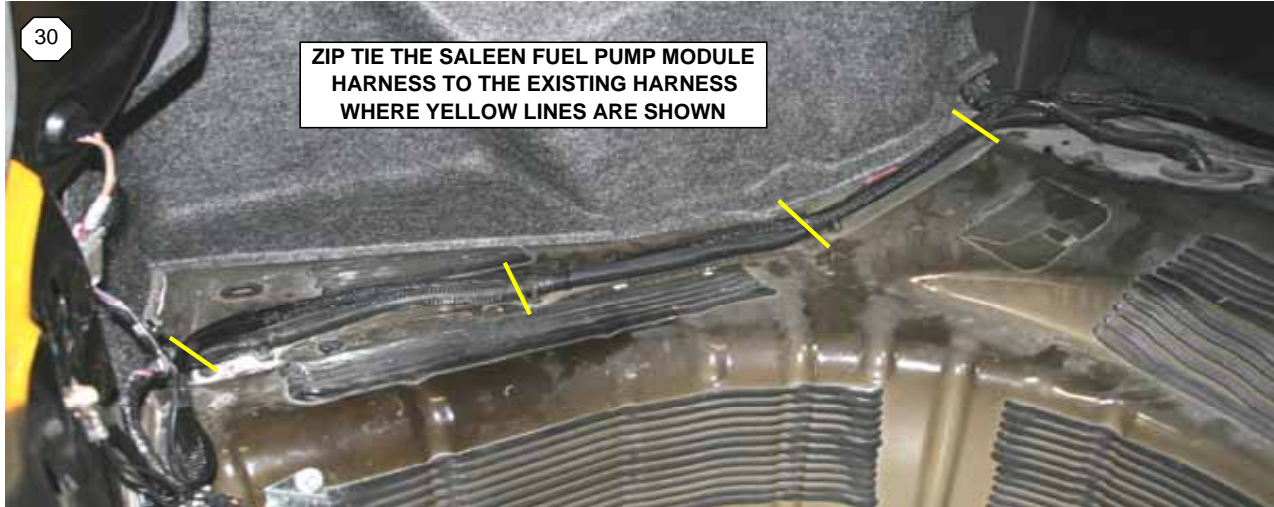

ZIP TIE THE SALEEN FUEL PUMP MODULE HARNESS TO THE EXISTING HARNESS WHERE YELLOW LINES ARE SHOWN

30

ITEM	PART NUMBER	QTY.	DESCRIPTION
A	00-9007-C10122*	4	7" Zip Tie

TORQUE	
1	91 +/- 13.6 Lb-ft



		11/9/2007	Rev: Draft - Approved By Doc & Data Control	AJF			CLIENT	PROGRAM
							SALEEN (INTERNAL)	S302 EXTREME
							PROCESS NAME	
							FUEL PUMP HARNESS INSTALLATION	
							PROCESS NUMBER	PAGE
							S302E-LINE-1150	3 of 9
CHANGE	PROCESS CHANGE NUMBER	DATE	REVISION	DRAWN BY	ENG APPR	MNF APPR		



INSPECTION



TORQUE



CRITICAL PROCESS



ITEM NUMBER



OPERATION

*if an operation cannot be completed, contact a supervisor.

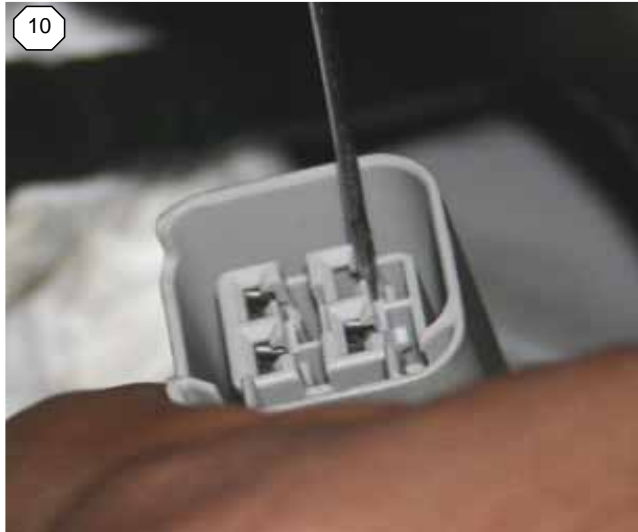

10

Locate the rubber plug under the LH rear seat bottom and remove. Locate the stock fuel pump harness connector and disconnect the stock fuel pump connector. Remove the blue plastic insert to expose the pins. Then use a pick to remove the wires from the connector. Once all the wires are removed (effectively separating the connector from the harness), discard the connector.

20

Remove the blue plastic insert and grey plastic cap of the Saleen harness fuel pump connector. De-pin the Saleen harness connector, but keep the connector and its parts, they will be re-used.

30

Once both harnesses are de-pinned, remove the grommet from the stock harness.

40

Slide both the rubber grommet (removed in **OPERATION 30**) and the rubber plug (removed in **OPERATION 10**) over both harnesses.

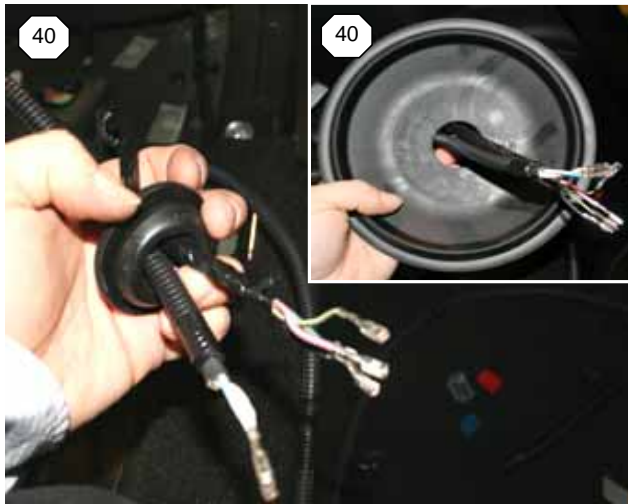
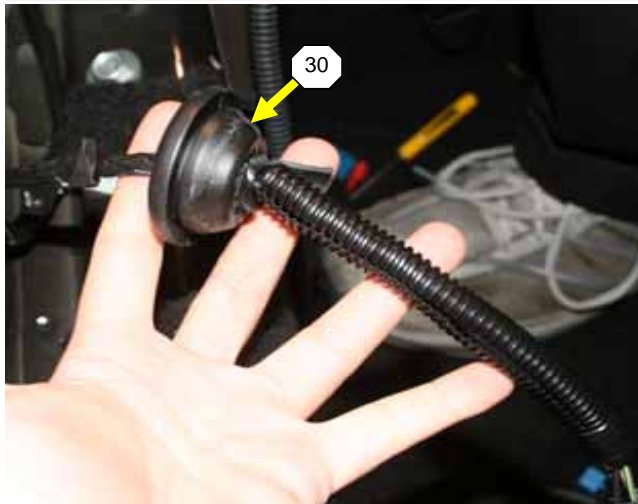

ITEM	PART NUMBER	QTY.	DESCRIPTION

TORQUE



		11/9/2007	Rev: Draft - Approved By Doc & Data Control	AJF		
1	PROCESS ALL	2/21/2008	Rev: 1 - Changed Process To Reflect New Level Fuel Harness	AJF		
CHANGE	PROCESS CHANGE NUMBER	DATE	REVISION	DRAWN BY	ENG APPR	MNF APPR

CLIENT	PROGRAM
SALEEN (INTERNAL)	S302 EXTREME
PROCESS NAME	
FUEL PUMP HARNESS INSTALLATION	
PROCESS NUMBER	PAGE
S302E-LINE-1150	4 of 9

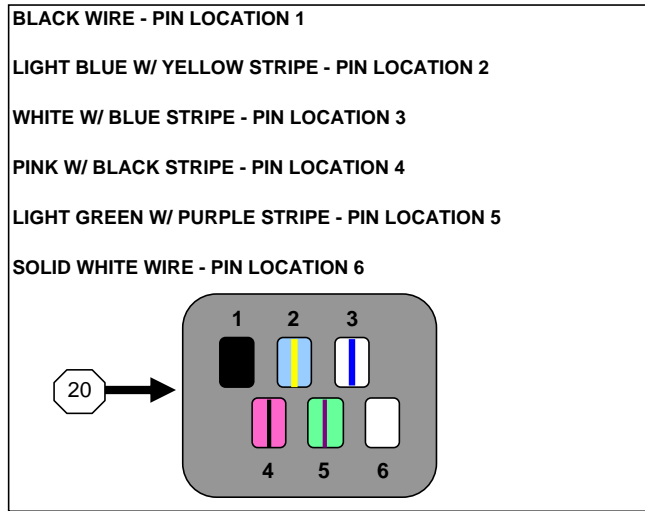
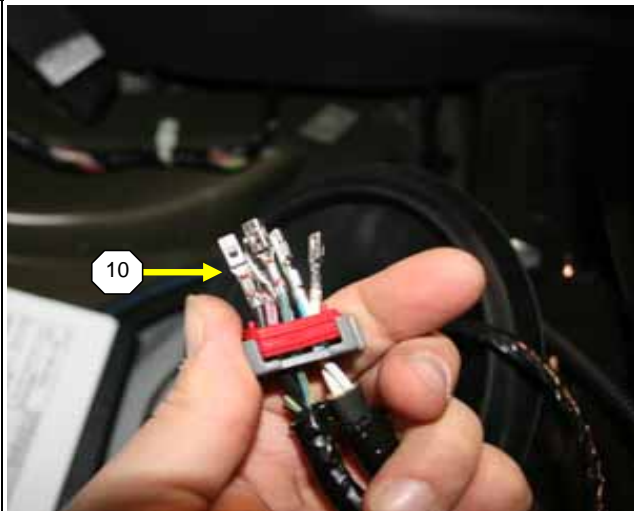

10 Slide the grey plastic cap from the Saleen fuel pump connector over the Saleen fuel harness pins and the stock harness pins. Then slide the red cable seal for the connector over the pins of both harnesses. Make sure the wires are in the correct position through the cap and cable seal. To verify, look at the diagram shown to the left.

20 Insert each pin from both the stock and Saleen fuel harnesses into the Saleen harness connector. Refer to the diagram on the left to verify the pin positions. The diagram is how the pin position should appear from the grey cap side (back side) of the connector. Make sure each pin is fully engaged (there should be an audible "click" when each pin is fully engaged). Once the connector is pinned install the cable seal and grey cap, and then the blue lock at the front of the connector.

30 Plug the newly pinned connector into the fuel pump. Make sure the connector is fully engaged, and then slide the red locking tab into the lock position.

40 Push the rubber plug into the floor pan under the rear seat. Slide the grommet into position and tape it to both harnesses on both sides of the grommet. Then seat the grommet into the top of the rubber plug.

ITEM	PART NUMBER	QTY.	DESCRIPTION

TORQUE



		11/9/2007	Rev: Draft - Approved By Doc & Data Control	AJF		
1	PROCESS ALL	2/21/2008	Rev: 1 - Altered Process To Reflect New Level Harness	AJF		
CHANGE	PROCESS CHANGE NUMBER	DATE	REVISION	DRAWN BY	ENG APPR	MNF APPR

CLIENT	PROGRAM
SALEEN (INTERNAL)	S302 EXTREME
PROCESS NAME	
FUEL PUMP HARNESS INSTALLATION	
PROCESS NUMBER	PAGE
S302E-LINE-1150	5 of 9



INSPECTION



TORQUE



CRITICAL PROCESS



ITEM NUMBER



OPERATION

*if an operation cannot be completed, contact a supervisor.

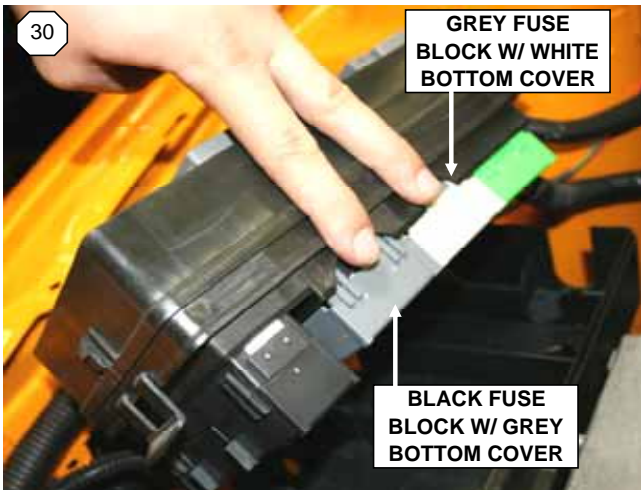
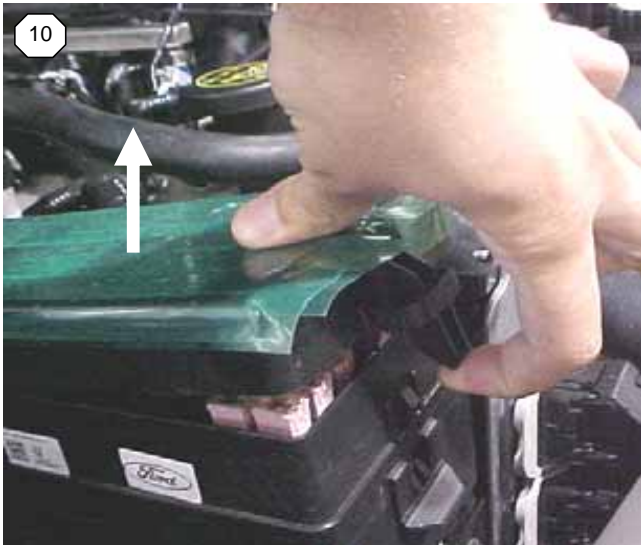

- 10 Proceed to the engine compartment and locate the fuse box (just in front of the passenger (RH) strut tower). Remove the cover by pulling up on two tabs (one at the front of the box and one at the back). The cover will lift off.
- 20 Lift the fuse panel out of the fuse box by lifting up on two more tabs (located at the front and back of the fuse box, just under the fuse box cover tabs).
- 30 Locate both the black fuse block with the grey bottom cover & the grey fuse block with the white bottom.
- 40 Remove both the **black fuse block w/ grey bottom cover** & the **grey fuse block w/ white bottom** by backing off the locking studs on the top of the fuse panel (there is one locking stud per fuse block).

ITEM	PART NUMBER	QTY.	DESCRIPTION

TORQUE	

SALEEN

		11/9/2007	Rev: Draft - Approved By Doc & Data Control	AJF			CLIENT	PROGRAM
							SALEEN (INTERNAL)	S302 EXTREME
							PROCESS NAME	
							FUEL PUMP HARNESS INSTALLATION	
							PROCESS NUMBER	PAGE
							S302E-LINE-1150	6 of 9
CHANGE	PROCESS CHANGE NUMBER	DATE	REVISION	DRAWN BY	ENG APPR			



INSPECTION



TORQUE



CRITICAL PROCESS



ITEM NUMBER



OPERATION

*if an operation cannot be completed, contact a supervisor.

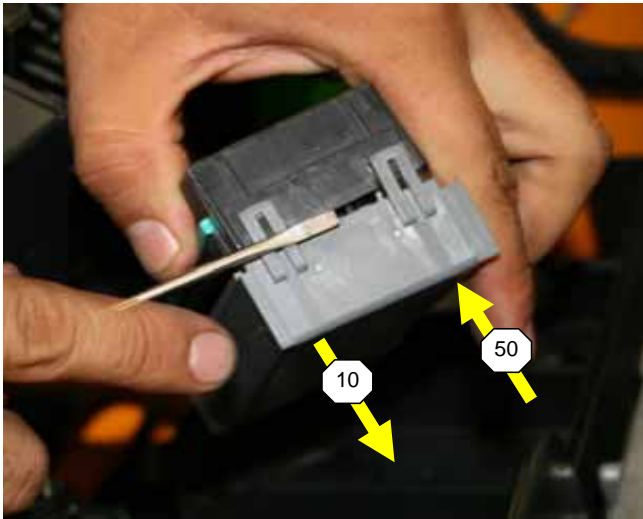

10

50

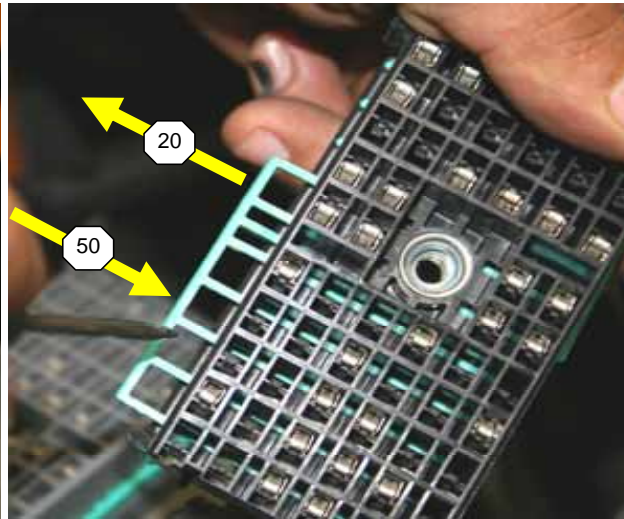

20

50

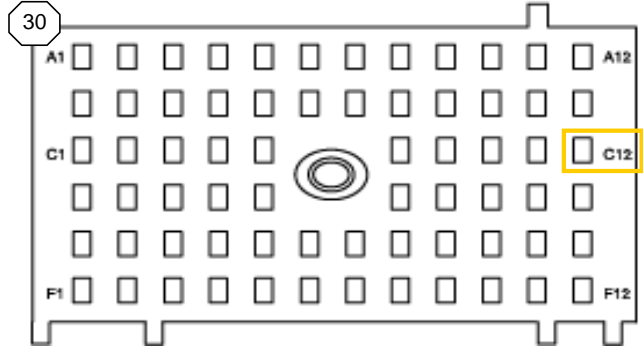

30

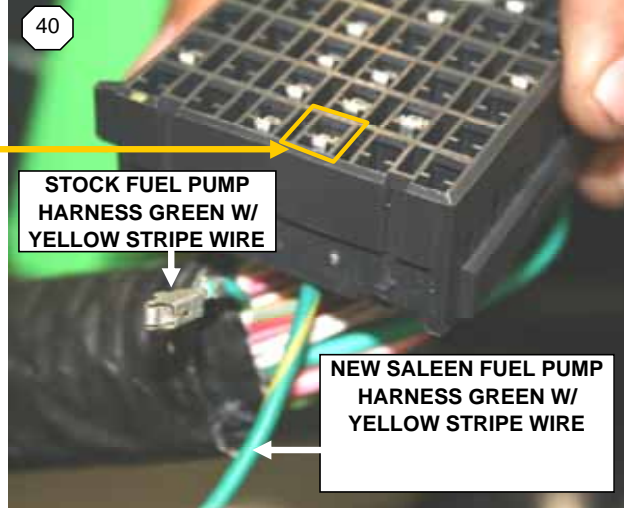

40

STOCK FUEL PUMP HARNESS GREEN W/ YELLOW STRIPE WIRE

NEW SALEEN FUEL PUMP HARNESS GREEN W/ YELLOW STRIPE WIRE

10

Once the black fuse block is unbolted, pull the block out of the fuse panel. Use a screw driver to disengage the locking tabs holding the grey cover on to the black fuse block, and remove the cover.

20

Remove the green locking clip holding the wires into the block.

30

Locate pin location **C-12** and remove the (dk. green w/ yellow stripe) wire from the fuse block.

40

Insert the green wire from the Saleen harness into that pin location.

50

Slide the green locking clip back into the fuse block. Then clip the grey cover back onto the bottom of the fuse block.

ITEM	PART NUMBER	QTY.	DESCRIPTION

TORQUE



		11/9/2007	Rev: Draft - Approved By Doc & Data Control	AJF			
CHANGE	PROCESS CHANGE NUMBER	DATE	REVISION	DRAWN BY	ENG APPR		

CLIENT	PROGRAM
SALEEN (INTERNAL)	S302 EXTREME
PROCESS NAME	
FUEL PUMP HARNESS INSTALLATION	
PROCESS NUMBER	PAGE
S302E-LINE-1150	7 of 9



INSPECTION



TORQUE



CRITICAL PROCESS



ITEM NUMBER



OPERATION

*if an operation cannot be completed, contact a supervisor.

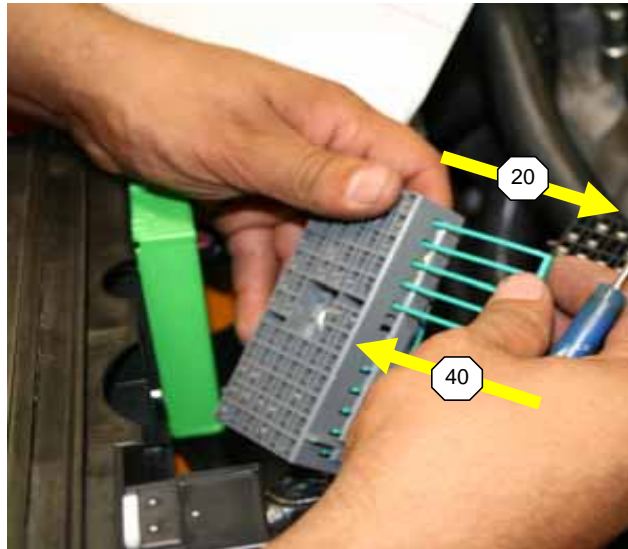
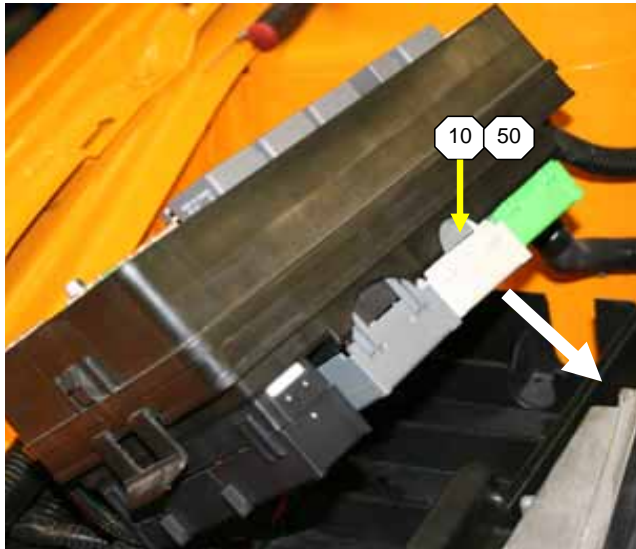

10

Pull the grey fuse block out of the fuse panel. Use a screw driver to disengage the locking tabs holding the white cover on to the grey fuse block, and remove the cover.

20

Remove the green locking clip holding the wires into the block.

30

Locate pin location **A-7** and insert the red wire from the Saleen fuel pump harness. There is no wire to remove from this location.

40

Once the red wire is inserted in pin location **A-7**, slide the green locking clip back into the grey fuse block.

50

Snap the white cover back onto the grey fuse block.

30

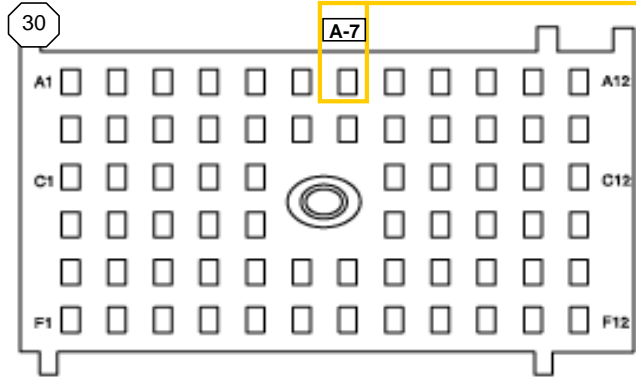

Pin	Circuit	Circuit Function
A7	-	not used



30

ITEM	PART NUMBER	QTY.	DESCRIPTION

TORQUE



		11/9/2007	Rev: Draft - Approved By Doc & Data Control	AJF			

CLIENT	PROGRAM
SALEEN (INTERNAL)	S302 EXTREME
PROCESS NAME	
FUEL PUMP HARNESS INSTALLATION	
PROCESS NUMBER	PAGE
S302E-LINE-1150	8 of 9

CHANGE	PROCESS CHANGE NUMBER	DATE	REVISION	DRAWN BY	ENG APPR	MAN APPR



INSPECTION



TORQUE



CRITICAL PROCESS



ITEM NUMBER



OPERATION

*if an operation cannot be completed, contact a supervisor.

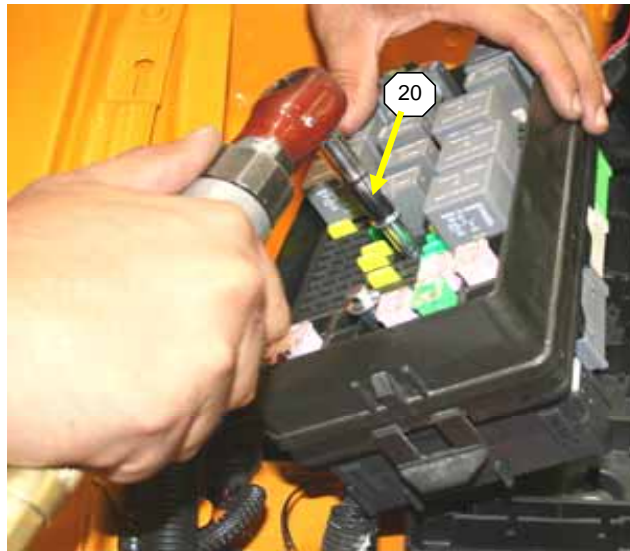
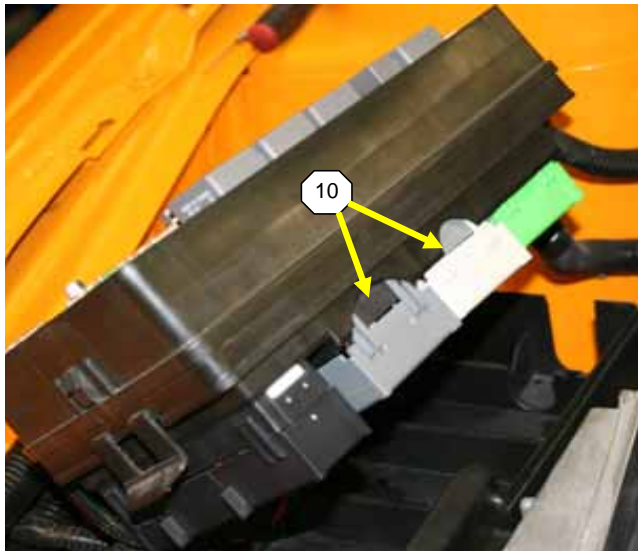

10 Make sure both the black and grey fuse blocks are inserted back into the fuse panel positioned as shown.

20 Secure the blocks in place by tightening the locking studs that were loosened previously to remove the fuse blocks.

30 Look to make sure all of the wires are routed through the ports in the side of the fuse panel (ports face the fender), and that no wires are going to be pinched when the fuse panel is clipped back in to place. The fuel pump harness will be following the wire harness that exits the port closest to the front of the vehicle. Snap the fuse panel back into the fuse box. Make sure the two tabs (one on the front and one on the back) are fully engaged.

40 Re-install the fuse box lid onto the fuse box. There are two clips (one on the front and one on the back above the fuse panel clips) that need to be clipped in. Make sure the clips are fully engaged.



ITEM	PART NUMBER	QTY.	DESCRIPTION

TORQUE



		11/9/2007	Rev: Draft - Approved By Doc & Data Control	AJF		
CHANGE	PROCESS CHANGE NUMBER	DATE	REVISION	DRAWN BY	ENG APPR	MAN APPR

CLIENT	PROGRAM
SALEEN (INTERNAL)	S302 EXTREME
PROCESS NAME	
FUEL PUMP HARNESS INSTALLATION	
PROCESS NUMBER	PAGE
S302E-LINE-1150	9 of 9